

Reference Clock for WiFi Module.
 REF_CLK_32K <- REF_CLK_32K AG14 R126 UR1005 REF_CLKO_32K

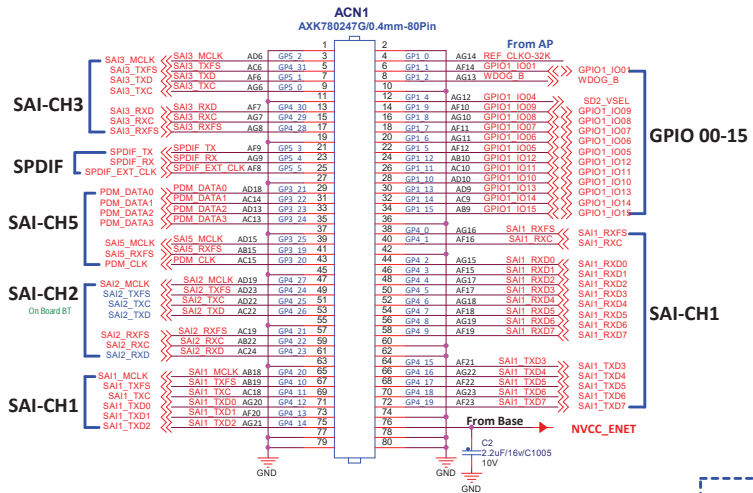

Module내부
 AF13 PMIC_nINT <- PMIC_nINT

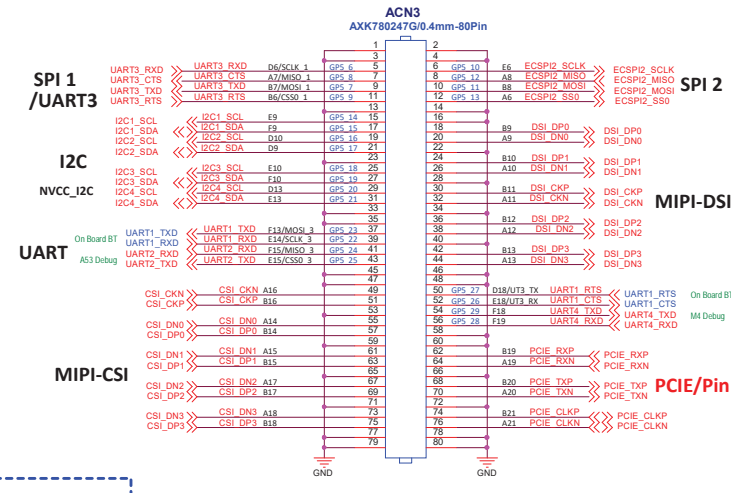
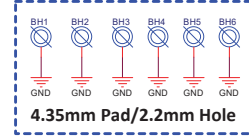
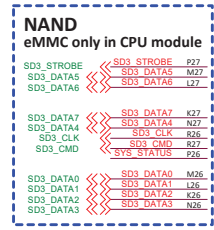

UART
 On Board B1
 A53 Debug

PCIE/Pin Change

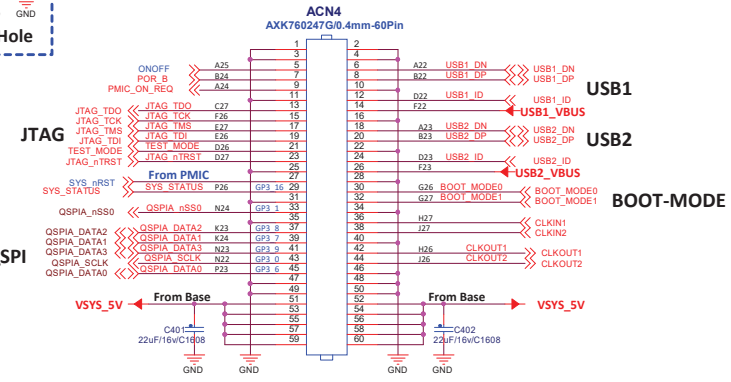
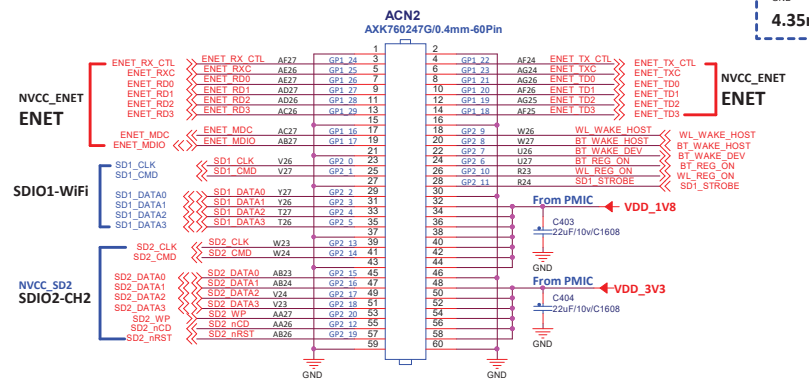

File: **MV-IMX8MM-CPU-V00**
 Size: Document Number
 Custom-Doc
 Date: Tuesday, May 14, 2019 Sheet 1 of 1